

PZ234E P-62x Positioning Systems User Manual

Version: 1.0.0

Date: 11.06.2012



This document describes the following products:

- **P-620, P-621, P-622, P-625, P-628, P-629**
PIHera piezo linear stage
P-620.1CD/.1CL/.10L/.1UD
P-621.1CD/.1CL/.10L/.1UD
P-622.1CD/.1CL/.10L/.1UD
P-625.1CD/.1CL/.10L/.1UD
P-628.1CD/.1CL/.10L/.1UD
P-629.1CD/.1CL/.10L/.1UD
- **P-620, P-621, P-622, P-625, P-628, P-629**
PIHera piezo XY stage
P-620.2CD/.2CL/.20L/.2UD
P-621.2CD/.2CL/.20L/.2UD
P-622.2CD/.2CL/.20L/.2UD
P-625.2CD/.2CL/.20L/.2UD
P-628.2CD/.2CL/.20L/.2UD
P-629.2CD/.2CL/.20L/.2UD
- **P-620, P-621, P-622**
PIHera precision Z stage
P-620.ZCD/.ZCL/.Z0L/.ZUD
P-621.ZCD/.ZCL/.Z0L/.ZUD
P-622.ZCD/.ZCL/.Z0L/.ZUD

.1CD/.2CD/.ZCD/.1UD/.2UD/.ZUD
= with Sub-D connector
.1CL/.2CL/.ZCL/.10L/.20L/.Z0L
= with LEMO connector



Physik Instrumente (PI) GmbH & Co. KG is the owner of the following trademarks:
PI®, PIC®, PICMA®, PILine®, PIFOC®, PiezoWalk®, NEXACT®, NEXLINE®,
NanoCube®, NanoAutomation®, Picoactuator®, PInano®

The products described in this document are in part protected by the following patents:

German patent no. 10021919C2

German patent no. 10234787C1

German patent no. 10348836B3

German patent no. 102005015405B3

German patent no. 102007011652B4

US patent no. 7,449,077

Japanese patent no. 4667863

Chinese patent no. ZL03813218.4

© 2012 Physik Instrumente (PI) GmbH & Co. KG, Karlsruhe, Deutschland. The text, photographs and drawings in this manual are protected by copyright. With regard thereto, Physik Instrumente (PI) GmbH & Co. KG retains all the rights. Use of said text, photographs and drawings is permitted only in part and only upon citation of the source.

Original instructions

First printing: 11.06.2012

Document number: PZ234E, CBo, Version 1.0.0

Subject to change without notice. This manual is superseded by any new release. The latest release is available for download on our website (<http://www.pi.ws>).



Contents

1	About this Document	1
1.1	Goal and Target Audience of this User Manual	1
1.2	Symbols and Typographic Conventions	2
1.3	Other Applicable Documents	3
2	Safety	5
2.1	Intended Use	5
2.2	General Safety Instructions	6
2.2.1	Organizational Measures	6
2.2.2	Measures for Handling Vacuum-Compatible Products	7
2.2.3	Safety Measures during Installation	7
2.2.4	Measures during Start-Up and Operation	10
3	Product Description	13
3.1	Features and Applications	13
3.2	Model Overview	14
3.2.1	PIHera Piezo Linear Stage	14
3.2.2	PIHera Piezo XY Stage	16
3.2.3	PIHera Precision Z Stage	18
3.3	Product View	19
3.4	Scope of Delivery	20
3.5	Technical Features	21
3.5.1	Flexure Guides	21
3.5.2	Capacitive Sensors	21
4	Unpacking	23
5	Installation	25
5.1	General Notes on Installation	25
5.2	Fastening the Stage and Load	28
5.3	Connecting the P-62x to a Protective Earth Conductor	32
6	Start-up and Operation	37
6.1	General Notes on Start-Up and Operation	37
6.2	Operating the P-62x	40
6.3	Discharging the P-62x	40

7	Maintenance	41
7.1	General Notes on Maintenance	41
7.2	Cleaning the P-62x	41
8	Troubleshooting	43
9	Customer Service	45
10	Technical Data	47
10.1	Specifications	48
10.1.1	Data Table	48
10.1.2	Maximum Ratings	51
10.1.3	Ambient Conditions and Classifications	52
10.2	Dimensions	53
10.3	Pin Assignment	57
10.4	Suitable Piezo Controllers	59
11	Old Equipment Disposal	61
12	EC Declaration of Conformity	63

1 About this Document

In this Chapter

Goal and Target Audience of this User Manual	1
Symbols and Typographic Conventions	2
Other Applicable Documents.....	3

1.1 Goal and Target Audience of this User Manual

This user manual contains the necessary information for the intended use of the P-62x (x stands for the travel range; details can be found in the Model Overview (p. 14)).

It assumes that the reader has a fundamental understanding of basic servo systems as well as motion control concepts and applicable safety procedures.

For updated releases of this user manual, or if you have any questions, contact our customer service department (p. 45).

1.2 Symbols and Typographic Conventions

The following symbols and typographic conventions are used in this user manual:

CAUTION



Dangerous situation

If not avoided, the dangerous situation will result in minor injury.



- Actions to take to avoid the situation.

NOTICE



Dangerous situation

If not avoided, the dangerous situation will result in damage to the equipment.

- Actions to take to avoid the situation.

INFORMATION

Information for easier handling, tricks, tips, etc.

Symbol	Meaning
1.	Action consisting of several steps whose sequential order must be observed
2.	
➤	Action consisting of one or several steps whose sequential order is irrelevant
▪	List item
p. 5	Cross-reference to page 5
RS-232	Labeling of an operating element on the product (example: socket of the RS-232 interface)
	Warning sign on the product which refers to detailed information in this manual. The information marked with this warning sign must be observed.

1.3 Other Applicable Documents

The devices and software tools which are mentioned in this documentation are described in their own manuals.

For the latest versions of the user manuals contact our customer service department (p. 45).

Device	Document
E-610.00 Piezo Driver	PZ70E User Manual
E-625.CR Piezo Servo Controller	PZ166E User Manual
E-665.CR Piezo Servo Controller	PZ127E User Manual
E-609 OEM Piezo Controller	Technical Note E609T0001
E-709 Digital Piezo Controller	PZ222E User Manual
E-753 Digital Piezo Controller	PZ193E User Manual
E-712 Digital Multi-Channel Piezo Controller	PZ195E User Manual
E-725 Digital Multi-Channel Piezo Controller	PZ197E User Manual
E-761 Digital Multi-Channel Piezo Controller (PCI Card)	PZ164E User Manual
PIMikroMove	SM148E Software Manual
NanoCapture	SM71E Software Manual
P-5xx / P-6xx / P-7xx Piezo Positioning Systems	PZ240EK Short Instructions

2 Safety

In this Chapter

Intended Use	5
General Safety Instructions	6

2.1 Intended Use

The P-62x is a laboratory device as defined by DIN EN 61010-1. It is intended to be used in interior spaces and in an environment which is free of dirt, oil and lubricants.

Based on its design and realization, the P-62x is intended for fine positioning as well as the fast and precise movement of small objects. The specifications of the P-62x apply to horizontal mounting. Depending on the model, the motion is performed as follows:

- in one axis horizontally or vertically
- in two axes horizontally

Vertical mounting is only possible under certain conditions.

The intended use of the P-62x is only possible in combination with suitable electronics (p. 59) that is available from PI. The electronics is not included in the scope of delivery of the P-62x.

The electronics must provide the required operating voltages. To ensure proper performance of the servo-control system, the electronics must be able to read out and process the signals from the capacitive sensors.

2.2 General Safety Instructions

The P-62x is built according to state-of-the-art technology and recognized safety standards. Improper use can result in personal injury and/or damage to the P-62x.

- Only use the P-62x for its intended purpose, and only use it if it is in a good working order.
- Read the user manual.
- Immediately eliminate any faults and malfunctions that are likely to affect safety.

The operator is responsible for the correct installation and operation of the P-62x.

2.2.1 Organizational Measures

User manual

- Always keep this user manual next to the P-62x.
If the user manual is lost or damaged, contact our customer service department (p. 45).
- Add all information given by the manufacturer to the user manual, for example supplements or Technical Notes.
- Only use the device on the basis of the complete user manual. Missing information due to an incomplete user manual can lead to minor injury as well as property damage.
- Only install and operate the P-62x after having read and understood this user manual.

Personnel qualification

The P-62x may only be started up, operated, maintained and cleaned by authorized and qualified staff.

2.2.2 Measures for Handling Vacuum-Compatible Products

When handling the vacuum version of the stage, attention must be paid to appropriate cleanliness. At PI, all parts are cleaned before assembly. During assembly and measurement, powder-free gloves are worn. Afterwards, the stage is cleaned once again by wiping and shrink-wrapped twice in vacuum-compatible film.

- Only touch the stage with powder-free gloves.
- If necessary, wipe the stage clean after unpacking.

2.2.3 Safety Measures during Installation

If a protective earth conductor is not or not properly connected, dangerous touch voltages can occur and there is a risk of electric shock. In the case of malfunction or failure of the system, touching the P-62x can result in minor injuries.

- Connect the P-62x to a protective earth conductor (see p. 32) before start-up.
- Do **not** remove the protective earth conductor during operation.
- Use electrically conductive materials (e.g. screws and flat washers) for mounting the protective earth conductor.
- Make sure that the contact resistance is <0.1 ohm at 25 A at all connection points relevant for mounting the protective earth conductor.
- If the protective earth conductor has to be temporarily removed (e.g. for modifications), reconnect the P-62x to the protective earth conductor before starting it up again.

The P-62x is driven by piezo actuators. Temperature changes and compressive stresses can induce charges in piezo actuators. After being disconnected from the electronics, piezo actuators can also stay charged for several hours. Touching or short-circuiting the contacts in the connector of the P-62x can lead to minor injuries. In addition, the piezo actuators can be destroyed by an abrupt contraction.

- Do **not** open the P-62x.
- Discharge the piezo actuators of the stage before installation:
Connect the stage to the switched-off PI controller, which is equipped with an internal discharge resistor.
- Do **not** pull out the connector from the electronics during operation.

For stages with Sub-D connector:

Touching the contacts in the connector can lead to an electric shock (max. 130 V DC) and minor injuries.

- Do **not** touch the contacts in the connector.
- Secure the connector of the stage with screws against being pulled out of the controller.

Unsuitable cables can damage the electronics.

- Only use cables from PI for connecting the P-62x to the electronics.

Mechanical forces can damage or misalign the P-62x.

- Avoid impacts that affect the P-62x.
- Do not drop the P-62x.
- Do **not** exceed the maximum permissible compressive/tensile stress.
- If you want to mount the P-62x vertically, contact our customer service department (p. 45).

Incorrect mounting can warp the base body. Warping of the base body will reduce accuracy.

- Mount the P-62x on a flat surface. The recommended flatness for the surface is 20 µm.
- For applications with great temperature changes:
Only mount the P-62x on surfaces that have the same or similar thermal expansion properties as the P-62x (e.g. surfaces made of aluminum).

The P-62x can be damaged by screws that are too long and parts that are wrongly mounted.

- When mounting the P-62x on a surface, make sure that the mounting screws do not interfere with the motion of the stage. The screw heads must not protrude from the counter-sunk holes.
- Note the depth of the mounting holes in the moving platform.
- Only use screws of the correct length for the respective mounting holes.
- Only mount the P-62x and the loads on the P-62x using the mounting fixtures (holes) intended for this purpose.

Incorrectly tightened screws can cause damage. If the torque is too low, screws and parts can become loose and endanger the application. If the torque is too high, parts (e.g. screws, threaded holes) can be damaged.

- Observe the torque range given for the used screws during installation (see p. 27).

2.2.4 Measures during Start-Up and Operation

- Do not start up the P-62x until it is fully mounted and connected.

If a protective earth conductor is not or not properly connected, dangerous touch voltages can occur and there is a risk of electric shock. In the case of malfunction or failure of the system, touching the P-62x can result in minor injuries.

- Only operate the P-62x when a protective earth conductor (see p. 32) is connected.

The P-62x is driven by piezo actuators. Temperature changes and compressive stresses can induce charges in piezo actuators. After being disconnected from the electronics, piezo actuators can also stay charged for several hours. Touching or short-circuiting the contacts in the connector of the P-62x can lead to minor injuries. In addition, the piezo actuators can be destroyed by an abrupt contraction.

- Do **not** open the P-62x.
- Discharge the piezo actuators of the stage before installation:
Connect the stage to the switched-off PI controller, which is equipped with an internal discharge resistor.
- Do **not** pull out the connector from the electronics during operation.

For stages with Sub-D connector:

Touching the contacts in the connector can lead to an electric shock (max. 130 V DC) and minor injuries.

- Do **not** touch the contacts in the connector.
- Secure the connector of the stage with screws against being pulled out of the controller.

Operating voltages that are too high or incorrectly connected can cause damage to the P-62x.

- Only operate the P-62x with controllers/drivers and original accessories from PI.
- Do **not** exceed the operating voltage range (p. 51) for which the P-62x is specified.
- Only operate the P-62x when the operating voltage is properly connected; see "Pin Assignment" (p. 57).

In the case of P-62x stages with Sub-D connectors, ground loops can occur when the stage is grounded via the protective earth connection or the mounting holes and additionally by the shield of the connection cable for the electronics.

- If a ground loop occurs, contact our customer service department (p. 45).

Oscillations can cause irreparable damage to the stage. Oscillations are indicated by a humming and can result from the following causes:

- The load and/or dynamics of operation differ too much from the calibration settings.
- The stage is operated near its resonant frequency.

If you notice oscillations:

- If oscillations occur during closed-loop operation, switch the servo mode off immediately.
- If oscillations occur during open-loop operation, stop the stage immediately.

The P-62x achieves its positioning accuracy as a result of the optimized coordination of mechanical components and piezo actuators. Disassembly of the P-62x will cause the specified accuracies to be lost.

- Do **not** open the P-62x.

The use of the P-62x in environments that increase the electrical conductivity can lead to the destruction of the piezo actuator by electric flashovers. Electric flashovers can be caused by moisture, high humidity, liquids and conductive materials such as metal dust. In addition, electric flashovers can also occur in certain air pressure ranges due to the increased conductivity of the air.

- Avoid operating the P-62x in environments that can increase the electric conductivity.
- Only operate the P-62x within the permissible ambient conditions and classifications (see p. 52).
- For operation in vacuum below 0.1 hPa:
Do **not** operate the P-62x during evacuation.

The constant application of high voltage to piezo actuators can lead to leakage currents and flashovers that destroy the ceramic.

If the P-62x is not used, but the controller is to remain switched on to ensure temperature stability:

In closed-loop operation:

1. Switch the servo mode off on the controller (open-loop operation).
2. Set the piezo voltage to 0 V on the controller.

In open-loop operation:

- Set the piezo voltage to 0 V on the controller.

3 Product Description

In this Chapter

Features and Applications	13
Model Overview	14
Product View	19
Scope of Delivery	20
Technical Features	21

3.1 Features and Applications

P-62x PIHera stages use PICMA® piezo actuators that allow a compact design and low profile.

PIHera stages offer long travel ranges with a subnanometer resolution. They are equipped with a particularly stiff and frictionless system of flexure guides that allow a high guiding accuracy.

The stages can be combined into compact XYZ systems. P-62x.ZCD and P-62x.ZCL stages are available for the vertical axis.

Vacuum-compatible versions of the P-62x are available on request.

3.2 Model Overview

The following standard versions of the P-62x are available:

3.2.1 PIHera Piezo Linear Stage

Model	Description
P-620.1CD	Precise PIHera Linear Nanopositioning System, 50 μm , Direct Metrology, Capacitive Sensor, Sub-D Connector
P-620.1CL	Precise PIHera Linear Nanopositioning System, 50 μm , Direct Metrology, Capacitive Sensor, LEMO Connector
P-620.10L	Precise PIHera Linear Nanopositioning System, 60 μm , Open-Loop, LEMO Connector
P-620.1UD	Precise PIHera Linear Nanopositioning System, 50 μm , Direct Metrology, Capacitive Sensor, Sub-D Connector, Vacuum Compatible to 10^{-9} hPa
P-621.1CD	Precise PIHera Linear Nanopositioning System, 100 μm , Direct Metrology, Capacitive Sensor, Sub-D Connector
P-621.1CL	Precise PIHera Linear Nanopositioning System, 100 μm , Direct Metrology, Capacitive Sensor, LEMO Connector
P-621.10L	Precise PIHera Linear Nanopositioning System, 120 μm , Open-Loop, LEMO Connector
P-621.1UD	Precise PIHera Linear Nanopositioning System, 100 μm , Direct Metrology, Capacitive Sensor, Sub-D Connector, Vacuum Compatible to 10^{-9} hPa
P-622.1CD	Precise PIHera Linear Nanopositioning System, 250 μm , Direct Metrology, Capacitive Sensor, Sub-D Connector
P-622.1CL	Precise PIHera Linear Nanopositioning System, 250 μm , Direct Metrology, Capacitive Sensor, LEMO Connector
P-622.10L	Precise PIHera Linear Nanopositioning System, 300 μm , Open-Loop, LEMO Connector
P-622.1UD	Precise PIHera Linear Nanopositioning System, 250 μm , Direct Metrology, Capacitive Sensor, Sub-D Connector, Vacuum Compatible to 10^{-9} hPa
P-625.1CD	Precise PIHera Linear Nanopositioning System, 500 μm , Direct Metrology, Capacitive Sensor, Sub-D Connector

Model	Description
P-625.1CL	Precise PIHera Linear Nanopositioning System, 500 μm , Direct Metrology, Capacitive Sensor, LEMO Connector
P-625.10L	Precise PIHera Linear Nanopositioning System, 600 μm , Open-Loop, LEMO Connector
P-625.1UD	Precise PIHera Linear Nanopositioning System, 500 μm , Direct Metrology, Capacitive Sensor, Sub-D Connector, Vacuum Compatible to 10^{-9} hPa
P-628.1CD	Precise PIHera Linear Nanopositioning System, 800 μm , Direct Metrology, Capacitive Sensor, Sub-D Connector
P-628.1CL	Precise PIHera Linear Nanopositioning System, 800 μm , Direct Metrology, Capacitive Sensor, LEMO Connector
P-628.10L	Precise PIHera Linear Nanopositioning System, 950 μm , Open-Loop, LEMO Connector
P-628.1UD	Precise PIHera Linear Nanopositioning System, 800 μm , Direct Metrology, Capacitive Sensor, Sub-D Connector, Vacuum Compatible to 10^{-9} hPa
P-629.1CD	PIHera Linear Piezo Nanopositioning Stage, 1500 μm , Capacitive Sensor, Sub-D Connector
P-629.1CL	PIHera Linear Piezo Nanopositioning Stage, 1500 μm , Capacitive Sensor, LEMO Connector
P-629.10L	Precise PIHera Linear Nanopositioning System, 1800 μm , Open-Loop, LEMO Connector
P-629.1UD	PIHera Linear Piezo Nanopositioning Stage, 1500 μm , Capacitive Sensor, Sub-D Connector, Vacuum Compatible to 10^{-9} hPa

3.2.2 PIHera Piezo XY Stage

Model	Description
P-620.2CD	Precise PIHera XY Nanopositioning System, 50 x 50 μm , Direct Metrology, Capacitive Sensors, Sub-D Connector
P-620.2CL	Precise PIHera XY Nanopositioning System, 50 x 50 μm , Direct Metrology, Capacitive Sensors, LEMO Connector
P-620.20L	Precise PIHera XY Nanopositioning System, 60 x 60 μm , Open-Loop, LEMO Connector
P-620.2UD	Precise PIHera XY Nanopositioning System, 50 x 50 μm , Direct Metrology, Capacitive Sensors, Sub-D Connector, Vacuum Compatible to 10^{-9} hPa
P-621.2CD	Precise PIHera XY Nanopositioning System, 100 x 100 μm , Direct Metrology, Capacitive Sensors, Sub-D Connector
P-621.2CL	Precise PIHera XY Nanopositioning System, 100 x 100 μm , Direct Metrology, Capacitive Sensors, LEMO Connector
P-621.20L	Precise PIHera XY Nanopositioning System, 120 x 120 μm , Open-Loop, LEMO Connector
P-621.2UD	Precise PIHera XY Nanopositioning System, 100 x 100 μm , Direct Metrology, Capacitive Sensors, Sub-D Connector, Vacuum Compatible to 10^{-9} hPa
P-622.2CD	Precise PIHera XY Nanopositioning System, 250 x 250 μm , Direct Metrology, Capacitive Sensors, Sub-D Connector
P-622.2CL	Precise PIHera XY Nanopositioning System, 250 x 250 μm , Direct Metrology, Capacitive Sensors, LEMO Connector
P-622.20L	Precise PIHera XY Nanopositioning System, 300 x 300 μm , Open-Loop, LEMO Connector
P-622.2UD	Precise PIHera XY Nanopositioning System, 250 x 250 μm , Direct Metrology, Capacitive Sensors, Sub-D Connector, Vacuum Compatible to 10^{-9} hPa
P-625.2CD	Precise PIHera XY Nanopositioning System, 500 x 500 μm , Direct Metrology, Capacitive Sensors, Sub-D Connector
P-625.2CL	Precise PIHera XY Nanopositioning System, 500 x 500 μm , Direct Metrology, Capacitive Sensors, LEMO Connector
P-625.20L	Precise PIHera XY Nanopositioning System, 600 x 600 μm , Open-Loop, LEMO Connector

Model	Description
P-625.2UD	Precise PIHera XY Nanopositioning System, 500 x 500 μm , Direct Metrology, Capacitive Sensors, Sub-D Connector, Vacuum Compatible to 10^{-9} hPa
P-628.2CD	Precise PIHera XY Nanopositioning System, 800 x 800 μm , Direct Metrology, Capacitive Sensors, Sub-D Connector
P-628.2CL	Precise PIHera XY Nanopositioning System, 800 x 800 μm , Direct Metrology, Capacitive Sensors, LEMO Connector
P-628.20L	Precise PIHera XY Nanopositioning System, 1000 x 1000 μm , Open-Loop, LEMO Connector
P-628.2UD	Precise PIHera XY Nanopositioning System, 800 x 800 μm , Direct Metrology, Capacitive Sensors, Sub-D Connector, Vacuum Compatible to 10^{-9} hPa
P-629.2CD	PIHera XY Piezo Nanopositioning Stage, 1500 x 1500 μm , Capacitive Sensors, Sub-D Connector
P-629.2CL	PIHera XY Piezo Nanopositioning Stage, 1500 x 1500 μm , Capacitive Sensors, LEMO Connector
P-629.20L	Precise PIHera XY Nanopositioning System, 1800 x 1800 μm , Open-Loop, LEMO Connector
P-629.2UD	PIHera XY Piezo Nanopositioning Stage, 1500 x 1500 μm , Capacitive Sensors, Sub-D Connector, Vacuum Compatible to 10^{-9} hPa

3.2.3 PIHera Precision Z Stage

Model	Description
P-620.ZCD	Precise PIHera Vertical Nanopositioning Stage, 50 μm , Capacitive Sensor, Sub-D Connector
P-620.ZCL	Precise PIHera Vertical Nanopositioning Stage, 50 μm , Capacitive Sensor, LEMO Connector
P-620.ZOL	Precise PIHera Vertical Nanopositioning Stage, 65 μm , Open-Loop, LEMO Connector
P-620.ZUD	PIHera Vertical Nanopositioning Stage, 50 μm , Direct Metrology, Capacitive Sensor, Vacuum Compatible to 10^{-9} hPa
P-621.ZCD	Precise PIHera Vertical Nanopositioning Stage, 100 μm , Capacitive Sensor, Sub-D Connector
P-621.ZCL	Precise PIHera Vertical Nanopositioning Stage, 100 μm , Capacitive Sensor, LEMO Connector
P-621.ZOL	Precise PIHera Vertical Nanopositioning Stage, 140 μm , Open-Loop, LEMO Connector
P-621.ZUD	Precise PIHera Vertical Nanopositioning Stage, 100 μm , Direct Metrology, Capacitive Sensor, Sub-D Connector, Vacuum Compatible to 10^{-9} hPa
P-622.ZCD	Precise PIHera Vertical Nanopositioning Stage, 250 μm , Capacitive Sensor, Sub-D Connector
P-622.ZCL	Precise PIHera Vertical Nanopositioning Stage, 250 μm , Capacitive Sensor, LEMO Connector
P-622.ZOL	Precise PIHera Vertical Nanopositioning Stage, 400 μm , Open-Loop, LEMO Connector
P-622.ZUD	Precise PIHera Vertical Nanopositioning Stage, 250 μm , Direct Metrology, Capacitive Sensor, Sub-D Connector, Vacuum Compatible to 10^{-9} hPa

3.3 Product View

The illustration serves as an example and can differ from your stage model.

- Observe the symbols on your device.

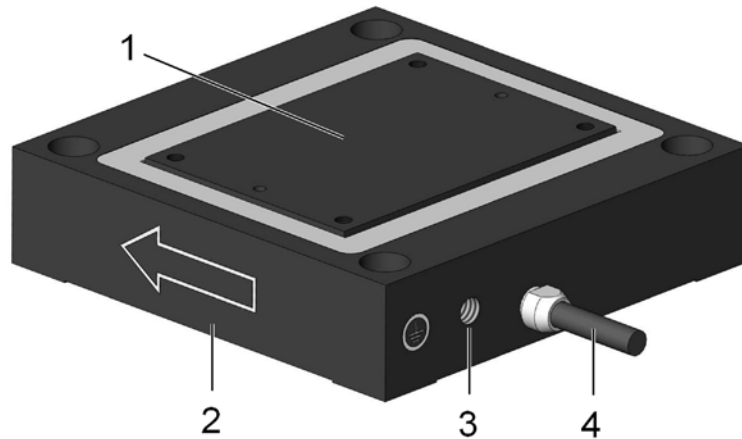

Figure 1: Example of product view

- 1 Moving platform
- 2 Base body
- 3 Protective earth connection
- 4 Connection cable to the electronics

3.4 Scope of Delivery

Order Number	Items	Model
P-62x	Stage according to order (p. 14)	-
000036450	M4 protective earth screw set, consisting of: <ul style="list-style-type: none"> ▪ 1 M4x8 flat-head screw with cross recess, ISO 7045 ▪ 2 safety washers ▪ 2 flat washers 	All models except for P-620
000036451	M2 protective earth screw set, consisting of: <ul style="list-style-type: none"> ▪ 4 M2x12 hex-head cap screws, ISO 4762 ▪ 4 safety washers ▪ 4 dowel pins Ø 1 m6 x 4, ISO 8734 ▪ 1 Allen wrench 	P-620
2491	Screw set, consisting of: <ul style="list-style-type: none"> ▪ 8 M3x10 hex-head cap screws, DIN 7984 ▪ 4 dowel pins Ø 1.5 m6 x 4, ISO 8734 ▪ 1 Allen wrench 	P-621.2xx P-622.2xx P-625.2xx P-628.2xx
000017112	Screw set, consisting of: <ul style="list-style-type: none"> ▪ 4 M4x16 hex-head cap screws, ISO 7984 ▪ 4 dowel pins Ø 1.5 m6 x 4, ISO 8734 ▪ 1 Allen wrench 	P-629.2xx
000011857	Screw set, consisting of: <ul style="list-style-type: none"> ▪ 4 M3x10 hex-head cap screws, DIN 7984 ▪ 4 dowel pins Ø 1.5 m6 x 4, ISO 8734 ▪ 1 Allen wrench 	P-621.Zxx P-622.Zxx
PZ240EK	Short instructions for piezo positioning systems	All models

3.5 Technical Features

3.5.1 Flexure Guides

The P-62x has flexure guides for frictionless motion and high guiding accuracies.

A flexure guide is an element which is free from static and sliding friction. It is based on the elastic deformation (bending) of a solid (e.g. steel) and does not have any rolling or sliding parts. Flexure elements have a high stiffness and load capacity and are very insensitive to shocks and vibrations. Flexure guides are maintenance- and wear-free. They are 100% vacuum compatible, function in a wide temperature range and do not require any lubricants.

3.5.2 Capacitive Sensors

Except for the models P-62x.x0L, all P-62x are equipped with capacitive sensors.

Capacitive sensors measure the position directly on the moving platform (direct metrology) and work without contact. Neither friction nor hysteresis interferes with the measurement, which allows excellent linearity values to be achieved in combination with the high position resolution. Capacitive sensors achieve the best resolution, stability and bandwidth.

4 Unpacking

INFORMATION

When handling the vacuum version of the stage, attention must be paid to appropriate cleanliness. At PI, all parts are cleaned before assembly. During assembly and measurement, powder-free gloves are worn. Afterwards, the stage is cleaned once again by wiping and shrink-wrapped twice in vacuum-compatible film.

- Only touch the stage with powder-free gloves.
- If necessary, wipe the stage clean after unpacking.

1. Unpack the P-62x with care.
2. Compare the contents against the items covered by the contract and against the packing list.
3. Inspect the contents for signs of damage. If parts are missing or you notice signs of damage, contact PI immediately.
4. Keep all packaging materials in case the product needs to be returned.

5 Installation

In this Chapter

General Notes on Installation	25
Fastening the Stage and Load	28
Connecting the P-62x to a Protective Earth Conductor	32

5.1 General Notes on Installation

CAUTION



Dangerous voltage and residual charge on piezo actuators!

The P-62x is driven by piezo actuators. Temperature changes and compressive stresses can induce charges in piezo actuators. After being disconnected from the electronics, piezo actuators can also stay charged for several hours. Touching or short-circuiting the contacts in the connector of the P-62x can lead to minor injuries. In addition, the piezo actuators can be destroyed by an abrupt contraction.

- Do **not** open the P-62x.
- Discharge the piezo actuators of the stage before installation:
Connect the stage to the switched-off PI controller, which is equipped with an internal discharge resistor.
- Do **not** pull out the connector from the electronics during operation.



For stages with Sub-D connector:

Touching the contacts in the connector can lead to an electric shock (max. 130 V DC) and minor injuries.

- Do **not** touch the contacts in the connector.
- Secure the connector of the stage with screws against being pulled out of the controller.

NOTICE**Destruction of the piezo actuator by electric flashovers!**

The use of the P-62x in environments that increase the electrical conductivity can lead to the destruction of the piezo actuator by electric flashovers. Electric flashovers can be caused by moisture, high humidity, liquids and conductive materials such as metal dust. In addition, electric flashovers can also occur in certain air pressure ranges due to the increased conductivity of the air.

- Avoid operating the P-62x in environments that can increase the electric conductivity.
- Only operate the P-62x within the permissible ambient conditions and classifications (see p. 52).
- For operation in vacuum below 0.1 hPa:
Do **not** operate the P-62x during evacuation.

NOTICE**Unsuitable cables!**

Unsuitable cables can damage the electronics.

- Only use cables from PI for connecting the P-62x to the electronics.

NOTICE**Damage due to incorrectly tightened screws**

Incorrectly tightened screws can cause damage. If the torque is too low, screws and parts can become loose and endanger the application. If the torque is too high, parts (e.g. screws, threaded holes) can be damaged.

- Observe the torque range given for the used screws during installation.

Torque for stainless steel screws (A2-70)

Screw size	Min. torque	Max. torque
M4	1.2 Nm	1.5 Nm
M3	0.6 Nm	0.8 Nm
M2.5	0.3 Nm	0.4 Nm
M2	0.15 Nm	0.2 Nm
M1.6	0.06 Nm	0.12 Nm

INFORMATION

Extended cables can affect the performance of the P-62x.

- Do **not** use cable extensions. If you need longer cables, contact our customer service department (p. 45).

5.2 Fastening the Stage and Load

NOTICE



Protruding screw heads!

Protruding screw heads can damage the P-62x.

- Ensure that the screws are completely fastened and that the screw heads do not protrude from the counter-sunk holes so that they do not interfere with the stage motion.

NOTICE



Screws that are too long!

The P-62x can be damaged by screws that are too long.

- Note the depth of the mounting holes in the moving platform (p. 53).
- Only use screws of the correct length for the respective mounting holes.

NOTICE



Warping of the base body!

Incorrect mounting can warp the base body. Warping of the base body will reduce accuracy.

- Mount the P-62x on a flat surface. The recommended flatness for the surface is 20 µm.
- For applications with great temperature changes:
Only mount the P-62x on surfaces that have the same or similar thermal expansion properties as the P-62x (e.g. surfaces made of aluminum).

NOTICE



Tensile stress on piezo actuator with vertical mounting!

When the stage is mounted vertically, a tensile stress can result in particular alignments that destroys the piezo actuator.

- If you want to mount the P-62x vertically, contact our customer service department (p. 45).

INFORMATION

In order to facilitate mounting with screws, you can fix the P-62x or loads using dowel pins. The P-62x has two holes each on the bottom side of the base body and on the moving platform to accommodate dowel pins.

INFORMATION

The positive direction of motion is away from the cable exit side.

Correct:

Figure 2: Centrally mounted load and center of load in the area of the moving platform

Incorrect:

Mounting the load incorrectly causes high strain on the flexure guides in the stage, high torques and the danger of oscillations.

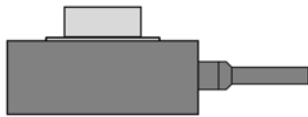
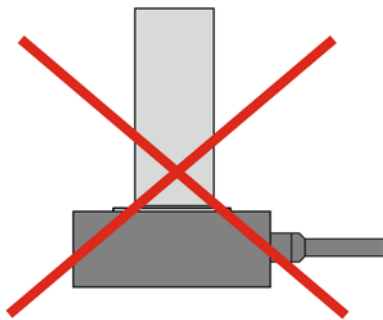

Figure 3: High set-up and center of load far above the moving platform

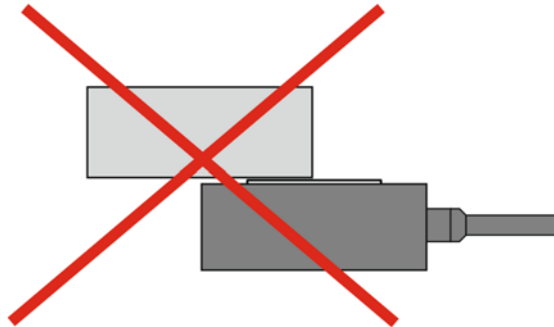

Figure 4: Long lever and center of load on the side of the moving platform

Prerequisite

- ✓ You have read and understood the General Notes on Installation (p. 25).

Tools and accessories

- When mounting a P-621.1xx, P-622.1xx, P-625.1xx, P-628.1xx or P-629.1xx:
 - Screws of appropriate size and length (dimensions see p. 53)
 - Optionally: Dowel pins of appropriate size and length (dimensions see p. 53)
- When mounting other P-62x models:
 - Supplied screws for mounting the stage on a surface
 - Optionally: Supplied dowel pins for aligning the stage or loads
- Suitable tools

Fastening the P-62x and load

1. Alignment (optional):
 - Align the stage using the locating holes in the base body (see p. 53) and suitable dowel pins.
 - Align the load using the locating holes in the moving platform of the P-62x (see p. 53) and suitable dowel pins.
2. Mounting:
 - Only mount the stage on the mounting holes intended for this purpose (see p. 53). If the stage is not equipped with a separate protective earth connection, follow the instructions for connecting the protective earth conductor via the mounting holes (p. 32) when fastening the stage.
 - Only fasten loads to the threaded holes intended for this purpose (see p. 53).

5.3 Connecting the P-62x to a Protective Earth Conductor

CAUTION



Risk of electric shock if the protective earth conductor is not connected!

If a protective earth conductor is not or not properly connected, dangerous touch voltages can occur and there is a risk of electric shock. In the case of malfunction or failure of the system, touching the P-62x can result in minor injuries.

- Connect the P-62x to a protective earth conductor before start-up.
- Do **not** remove the protective earth conductor during operation.
- Use electrically conductive materials (e.g. screws and flat washers) for mounting the protective earth conductor.
- Make sure that the contact resistance is <0.1 ohm at 25 A at all connection points relevant for mounting the protective earth conductor.
- If the protective earth conductor has to be temporarily removed (e.g. for modifications), reconnect the P-62x to the protective earth conductor before starting it up again.

NOTICE



Ground loops with double connection of protective earth conductor!

In the case of P-62x stages with Sub-D connectors, ground loops can occur when the stage is grounded via its protective earth connection or the mounting holes as well as by the shield of the connection cable for the electronics.

- If a ground loop occurs, contact our customer service department (p. 45).

INFORMATION

- Observe the applicable standards for mounting the protective earth conductor.

The connection of the P-62x to the protective earth conductor depends on the model:

- Models **with** separate protective earth connection (all except for P-620)
- Models **without** separate protective earth connection (only P-620)

Separate protective earth connection present

If a separate protective earth connection is present, it must be used.

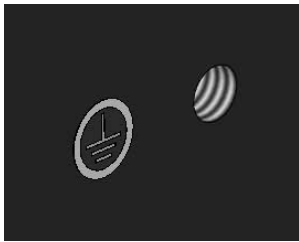

Figure 5: Protective earth connection

No separate protective earth connection present

If no separate protective earth connection is present, **all** mounting holes marked with the symbol for the protective earth conductor (⏚) must be used in order to ensure the proper connection of the protective earth conductor.

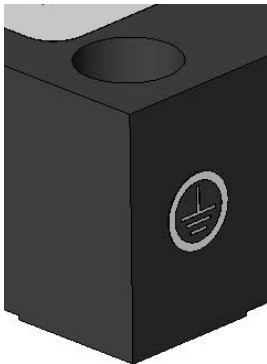

Figure 6: Mounting hole with symbol for the protective earth conductor

Tools and accessories

- Suitable protective earth conductor: Cross-sectional area of the cable $\geq 0.75 \text{ mm}^2$
- Suitable screwdriver
- All models except for P-620: Supplied M4 CE screw set for connecting the protective earth conductor

- When mounting a P-620:
 - Supplied dowel pins for aligning the stage on a surface
 - Supplied M2x12 screws and safety washers for mounting the stage on a surface
 - Suitable surface: The surface on which the P-620 is to be mounted must be connected to a suitable protective earth conductor. The contact surfaces with the stage, generally the holes for accommodating the mounting screws, must be sufficiently conductive.

Connecting the protective earth conductor to the separate protective earth connection (all models except for P-620)

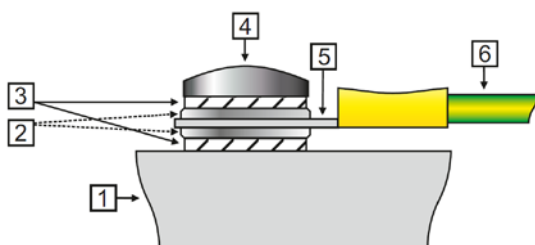

Figure 7: Recommended mounting of the protective earth conductor (profile view)

- 1 Case of the P-62x
- 2 Flat washer
- 3 Safety washer
- 4 Screw
- 5 Cable lug
- 6 Protective earth conductor

1. If necessary, fasten a suitable cable lug to the protective earth conductor.
2. Fasten the cable lug of the protective earth conductor to the M4 screw on the protective earth connection of the P-62x as shown in the profile view.
3. Tighten the M4 screw with at least three rotations and a torque of 1.2 Nm to 1.5 Nm.

Connecting the protective earth conductor via the mounting holes (only P-620)

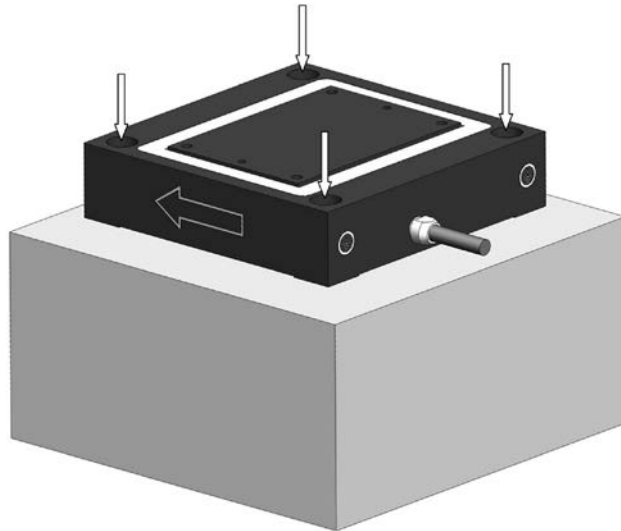

Figure 8: Stage on a surface that must be connected to a protective earth conductor; for mounting holes, see arrows.

1. Optionally: Align the stage using the locating holes in the base body (see p. 53) and the supplied dowel pins.
2. Mount the stage on an electrically conductive surface that is connected to a suitable protective earth conductor:
 - a) Place a safety washer on each M2x12 screw.
 - b) Insert a screw together with its respective safety washer into each of the four mounting holes (see white arrows in the illustration).
The mounting holes are each marked with the symbol for the protective earth conductor \oplus .
 - c) Tighten the four M2 screws each with at least three rotations and a torque of 0.15 Nm to 0.2 Nm.

6 Start-up and Operation

In this Chapter

General Notes on Start-Up and Operation	37
Operating the P-62x	40
Discharging the P-62x	40

6.1 General Notes on Start-Up and Operation

CAUTION



Risk of electric shock if the protective earth conductor is not connected!

If a protective earth conductor is not or not properly connected, dangerous touch voltages can occur and there is a risk of electric shock. In the case of malfunction or failure of the system, touching the P-62x can result in minor injuries.

- Connect the P-62x to a protective earth conductor (p. 32) before start-up.
- Do **not** remove the protective earth conductor during operation.
- If the protective earth conductor has to be temporarily removed (e.g. for modifications), reconnect the P-62x to the protective earth conductor before starting it up again.

CAUTION



Dangerous voltage and residual charge on piezo actuators!

The P-62x is driven by piezo actuators. Temperature changes and compressive stresses can induce charges in piezo actuators. After being disconnected from the electronics, piezo actuators can also stay charged for several hours. Touching or short-circuiting the contacts in the connector of the P-62x can lead to minor injuries. In addition, the piezo actuators can be destroyed by an abrupt contraction.

- Do **not** open the P-62x.
- Discharge the piezo actuators of the stage before installation:
Connect the stage to the switched-off PI controller, which is equipped with an internal discharge resistor.
- Do **not** pull out the connector from the electronics during operation.



For stages with Sub-D connector:

Touching the contacts in the connector can lead to an electric shock (max. 130 V DC) and minor injuries.

- Do **not** touch the contacts in the connector.
- Secure the connector of the stage with screws against being pulled out of the controller.

NOTICE



Destruction of the piezo actuator by electric flashovers!

The use of the P-62x in environments that increase the electrical conductivity can lead to the destruction of the piezo actuator by electric flashovers. Electric flashovers can be caused by moisture, high humidity, liquids and conductive materials such as metal dust. In addition, electric flashovers can also occur in certain air pressure ranges due to the increased conductivity of the air.

- Avoid operating the P-62x in environments that can increase the electric conductivity.
- Only operate the P-62x within the permissible ambient conditions and classifications (see p. 52).
- For operation in vacuum below 0.1 hPa:
Do **not** operate the P-62x during evacuation.

NOTICE**Destruction of the piezo actuator by continuously high voltage!**

The constant application of high voltage to piezo actuators can lead to leakage currents and flashovers that destroy the ceramic.

If the P-62x is not used, but the controller is to remain switched on to ensure temperature stability:

In closed-loop operation:

1. Switch the servo mode off on the controller (open-loop operation).
2. Set the piezo voltage to 0 V on the controller.

In open-loop operation:

- Set the piezo voltage to 0 V on the controller.

NOTICE**Uncontrolled oscillation!**

Oscillations can cause irreparable damage to the stage. Oscillations are indicated by a humming and can result from the following causes:

- The load and/or dynamics of operation differ too much from the calibration settings.
- The stage is operated near its resonant frequency.

If you notice oscillations:

- If oscillations occur during closed-loop operation, switch the servo mode off immediately.
- If oscillations occur during open-loop operation, stop the stage immediately.

INFORMATION

The positive direction of motion is away from the cable exit side.

INFORMATION

If your system was calibrated by PI, the piezo servo controller and the stage must not be exchanged or substituted.

- Take note of the assignment indicated by the serial numbers on the calibration label on the piezo servo controller.
- If the piezo servo controller or the stage has to be replaced, recalibrate the axis displacement (see controller manual) or contact our customer service department (p. 45).

INFORMATION

Sound and oscillations (e.g. loud talking, impacts) can interfere with the functioning of the P-62x.

- Avoid sound and oscillations during the operation of the stage.

INFORMATION

The expansion of the piezo actuators depends on the ambient temperature and can vary by up to 20% in the given temperature ranges.

6.2 Operating the P-62x

- Follow the instructions in the manual of the used piezo controller for start-up and operation of the P-62x.

6.3 Discharging the P-62x

The P-62x must be discharged before demounting. Demounting is necessary e.g. before cleaning or transporting the P-62x as well as for modifications. Discharging takes place via the internal discharge resistor of the PI controller.

Discharging a P-62x that is connected to the controller

1. When you operate the P-62x in closed-loop operation, switch the servo mode off on the controller (open-loop operation).
2. Set the piezo voltage to 0 V on the controller.

Discharging a P-62x that is not connected to the controller

- Connect the stage to the switched-off PI controller.

7 Maintenance

In this Chapter

General Notes on Maintenance.....	41
Cleaning the P-62x	41

7.1 General Notes on Maintenance

NOTICE



Misalignment from loosening screws!

The P-62x is maintenance-free and precisely aligned.

- Do not loosen any sealed screws on the P-62x.

7.2 Cleaning the P-62x

Prerequisites

- ✓ You have discharged the piezo actuators of the P-62x (see p. 40).
- ✓ You have disconnected the P-62x from the controller.

Cleaning the P-62x

- Clean the surface of the P-62x with a towel that is lightly dampened with a mild cleanser or disinfectant, with alcohol or with isopropanol.
- Do **not** do any ultrasonic cleaning.

8 Troubleshooting

Problem	Possible Causes	Solution
No or limited motion	The cable is not connected correctly	➤ Check the cable connections.
	Excessive load	➤ Do not exceed the compressive/tensile stress capacity according to the specifications (p. 48).
	The load was changed	➤ After changing the load to be moved, perform a zero-point adjustment (see controller manual).
Reduced accuracy	Warped base body	<ul style="list-style-type: none"> ➤ Mount the P-62x on an even surface. The recommended evenness of the surface is 20 µm. ➤ Mount the P-62x on a surface that has the same or similar thermal expansion properties as the P-62x (e.g. aluminum surface).
	P-62x or controller has been replaced	<p>When using analog controllers or stages without an ID chip, a recalibration is necessary after changing the P-62x or the controller.</p> <ul style="list-style-type: none"> ➤ Perform a recalibration of the axis displacement (see controller manual) or contact our customer service department (p. 45).
	Axes have been mixed up during connection	➤ When connecting the stage with the controller, observe the assignment of the axes. This assignment is indicated by labels on the devices.

Problem	Possible Causes	Solution
The stage starts oscillating or is positioned inaccurately	Servo-control parameters set incorrectly	<ul style="list-style-type: none"> ➤ Immediately switch off the servo mode of the affected stage axes. ➤ Check the settings of the servo-control parameters on the controller.
	Operation with resonant frequency	<ul style="list-style-type: none"> ➤ Do not operate the stage in open-loop operation with resonant frequency.
	The load was changed	<ul style="list-style-type: none"> ➤ Adjust the parameters on the controller according to the load change.

If the problem that occurred with your system is not listed in the table above or it cannot be solved as described, contact our customer service department (p. 45).

9 Customer Service

For inquiries and orders, contact your PI sales engineer or send us an e-mail (info@pi.ws).

If you have questions concerning your system, have the following information ready:

- Product codes and serial numbers of all products in the system
- Firmware version of the controller (if present)
- Version of the driver or the software (if present)
- Operating system on the PC (if present)

The latest versions of the relevant user manuals for your system are available for download on our website (<http://www.pi.ws>).

10 Technical Data

In this Chapter

Specifications	48
Dimensions	53
Pin Assignment.....	57
Suitable Piezo Controllers	59

10.1 Specifications

10.1.1 Data Table

	P-620.1CD P-620.1CL	P-621.1CD P-621.1CL	P-622.1CD P-622.1CL	P-625.1CD P-625.1CL	P-628.1CD P-628.1CL	P-629.1CD P-629.1CL	Unit	Tolerance
Active axes	X	X	X	X	X	X		
Motion and positioning								
Integrated sensor	Capacitive	Capacitive	Capacitive	Capacitive	Capacitive	Capacitive		
Open-loop travel, -20 to 120 V	60	120	300	600	950	1800	µm	min. (+20% / -0%)
Closed-loop travel	50	100	250	500	800	1500	µm	
Closed-loop / open-loop resolution	0.2 / 0.1	0.4 / 0.2	0.7 / 0.4	1.4 / 0.5	1.8 / 0.5	3 / 2	nm	typ.
Linearity error, closed-loop	0.02	0.02	0.02	0.03	0.03*	0.03**	%	typ.
Repeatability	±1	±1	±1	±5	±10	±14	nm	typ.
Pitch / yaw	±3	±3	±3	±6	±6	±30 / ±10	µrad	typ.
Mechanical properties								
Stiffness in motion direction	0.42	0.35	0.2	0.1	0.12	0.13	N/µm	±20%
Unloaded resonant frequency	1100	800	400	215	125	125	Hz	±20%
Resonant frequency @ 20 g	550	520	340	180	115	120	Hz	±20%
Resonant frequency @ 120 g	260	240	185	110	90	110	Hz	±20%
Push / pull force capacity in motion direction	10	10	10	10	10	10	N	max.
Load capacity	10	10	10	10	10	10	N	max.
Lateral force	10	10	10	10	10	8	N	max.
Drive properties								
Piezoceramics	PICMA® P-883	PICMA® P-885	PICMA® P-885	PICMA® P-885	PICMA® P-887	PICMA® P-888		
Electrical capacitance	0.35	1.5	3.1	6.2	19	52	µF	±20%
Dynamic operating current coefficient	0.9	1.9	1.9	1.6	3	4.3	µA / (Hz × µm)	±20%
Miscellaneous								
Operating temperature range	-20 to 80	-20 to 80	-20 to 80	-20 to 80	-20 to 80	-20 to 80	°C	
Material	Aluminum	Aluminum	Aluminum	Aluminum	Aluminum	Aluminum		
Dimensions	30 × 30 × 12	40 × 40 × 15	50 × 50 × 15	60 × 60 × 15	80 × 80 × 17	100 × 100 × 22.5	mm	
Mass	0.11	0.16	0.2	0.24	0.38	0.72	kg	±5%
Cable length	1.5	1.5	1.5	1.5	1.5	1.5	m	±10 mm
Sensor / voltage connection	CD versions: Sub-D special CL versions: LEMO							

Versions without a sensor are available under the P-62x.10L order numbers; operating temperature range -20 to 150°C.

Vacuum-compatible versions to 10⁻⁹ hPa are available under the P-62x.1UD order numbers.

The resolution of PI piezo nanopositioners is not limited by friction or stiction. Value given as noise with E-710 digital controller.

* With digital controller. With analog controllers 0.05%

** With digital controller. With analog controllers 0.07%

	P-620.2CD P-620.2CL	P-621.2CD P-621.2CL	P-622.2CD P-622.2CL	P-625.2CD P-625.2CL	P-628.2CD P-628.2CL	P-629.2CD P-629.2CL	Unit	Tolerance
Active axes	X, Y	X, Y	X, Y	X, Y	X, Y	X, Y		
Motion and positioning								
Integrated sensor	Capacitive	Capacitive	Capacitive	Capacitive	Capacitive	Capacitive		
Open-loop travel X, Y, -20 to 120 V	60	120	300	600	950	1800	µm	min. (+20% / -0%)
Closed-loop travel X, Y	50	100	250	500	800	1500	µm	
Open-loop resolution X, Y	0.1	0.2	0.4	0.5	0.5	2	nm	typ.
Closed-loop resolution X, Y	0.2	0.4	0.7	1.4	3.5	3.5	nm	typ.
Linearity error X, Y	0.02	0.02	0.02	0.03	0.03*	0.03**	%	typ.
Repeatability X, Y	±2	±2	±2	±5	±10	±14	nm	typ.
Pitch / yaw	±3	±3	±3	±3 / ±5	±20 / ±5	±30 / ±5	µrad	typ.
Mechanical properties								
Stiffness X, Y	0.22	0.25	0.2	0.1	0.05	0.1	N/µm	±20%
Unloaded resonant frequency X	575	420	225	135	75	60	Hz	±20%
Unloaded resonant frequency Y	800	535	300	195	105	100	Hz	±20%
Resonant frequency X @ 50 g	270	285	180	120	60	55	Hz	±20%
Resonant frequency Y @ 50 g	395	365	215	150	85	85	Hz	±20%
Resonant frequency X @ 100 g	285	220	160	105	55	50	Hz	±20%
Resonant frequency Y @ 100 g	300	285	175	125	75	80	Hz	±20%
Push / pull force capacity in motion direction	10 / 5	10 / 8	10 / 8	10 / 8	10 / 8	10 / 8	N	max.
Load capacity	10	10	10	10	10	10	N	max.
Lateral force	10	10	10	10	10	10	N	max.
Drive properties								
Piezoceramics	PICMA® P-883	PICMA® P-885	PICMA® P-885	PICMA® P-885	PICMA® P-887	PICMA® P-888		
Electrical capacitance in X, Y	0.35	1.5	3.1	6.2	19	52	µF	±20%
Dynamic operating current coefficient in X, Y	0.9	1.9	1.9	1.6	3	4.3	µA / (Hz × µm)	±20%
Miscellaneous								
Operating temperature range	-20 to 80	-20 to 80	-20 to 80	-20 to 80	-20 to 80	-20 to 80	°C	
Material	Aluminum	Aluminum	Aluminum	Aluminum	Aluminum	Aluminum		
Dimensions	30 × 30 × 21.5	40 × 40 × 25	50 × 50 × 25	60 × 60 × 25	80 × 80 × 25	100 × 100 × 40	mm	
Mass	0.195	0.295	0.348	0.43	0.7	1.37	kg	±5%
Cable length	1.5	1.5	1.5	1.5	1.5	1.5	m	±10 mm
Sensor / voltage connection	CD versions: Sub-D special CL versions: LEMO							

Versions without a sensor are available under the P-62x.20L order numbers; operating temperature range -20 to 150°C.

Vacuum-compatible versions to 10⁻⁹ hPa are available under the P-62x.2UD order numbers.

The resolution of PI piezo nanopositioners is not limited by friction or stiction. Value given as noise with E-710 digital controller.

* With digital controller. With analog controllers 0.05%



** With digital controller. With analog controllers 0.07%

	P-620.ZCD P-620.ZCL	P-621.ZCD P-621.ZCL	P-622.ZCD P-622.ZCL	Unit	Tolerance
Active axes	Z	Z	Z		
Motion and positioning					
Integrated sensor	Capacitive	Capacitive	Capacitive		
Open-loop travel, -20 to 120 V	65	140	400	μm	min. (+20% / -0%)
Closed-loop travel	50	100	250	μm	
Open-loop resolution	0.1	0.2	0.5	nm	typ.
Closed-loop resolution	0.2	0.3	1	nm	typ.
Linearity error	0.02	0.02	0.02	%	typ.
Repeatability	±1	±1	±1	nm	typ.
Tilting θ_x , θ_y	<20	<20	<80	μrad	typ.
Mechanical properties					
Stiffness	0.5	0.6	0.24	N/μm	±20%
Unloaded resonant frequency	1000	790	360	Hz	±20%
Resonant frequency @ 30 g	690	500	270	Hz	±20%
Push / pull force capacity	10 / 5	10 / 8	10 / 8	N	max.
Load capacity	10	10	10	N	max.
Lateral force	10	10	10	N	max.
Drive properties					
Ceramic type	PICMA® P-883	PICMA® P-885	PICMA® P-885		
Electrical capacitance	0.7	3	6.2	μF	±20%
Dynamic operating current coefficient	1.8	3.8	3.1	μA / (Hz × μm)	±20%
Miscellaneous					
Operating temperature range	-20 to 80	-20 to 80	-20 to 80	°C	
Material	Aluminum	Aluminum	Aluminum		
Dimensions	30 × 30 × 15	40 × 40 × 17.5	50 × 50 × 17.5	mm	
Mass	0.12	0.17	0.24	kg	±5%
Cable length	1.5	1.5	1.5	m	±10 mm
Sensor / voltage connection	CD versions: Sub-D special CL versions: LEMO				

Versions without a sensor are available under the P-62x.Z0L order numbers; operating temperature range -20 to 150°C.
Vacuum-compatible versions to 10⁻⁹ hPa are available under the P-62x.ZUD order numbers.

10.1.2 Maximum Ratings

P-62x stages are designed for the following operating parameters:

Stage	Maximum operating voltage 	Maximum operating frequency (unloaded) 	Maximum power consumption 
P-620.1xx	-20 to +120 V	367 Hz	3 W
P-621.1xx	-20 to +120 V	267 Hz	9 W
P-622.1xx	-20 to +120 V	133 Hz	9 W
P-625.1xx	-20 to +120 V	72 Hz	10 W
P-628.1xx	-20 to +120 V	42 Hz	18 W
P-629.1xx	-20 to +120 V	42 Hz	49 W
P-620.2xx	-20 to +120 V	267 Hz (in X and Y)	2 W (in X and Y)
P-621.2xx	-20 to +120 V	178 Hz (in X and Y)	6 W (in X and Y)
P-622.2xx	-20 to +120 V	100 Hz (in X and Y)	7 W (in X and Y)
P-625.2xx	-20 to +120 V	65 Hz (in X and Y)	9 W (in X and Y)
P-628.2xx	-20 to +120 V	35 Hz (in X and Y)	15 W (in X and Y)
P-629.2xx	-20 to +120 V	33 Hz (in X and Y)	38 W (in X and Y)
P-620.Zxx	-20 to +120 V	333 Hz	5 W
P-621.Zxx	-20 to +120 V	263 Hz	18 W
P-622.Zxx	-20 to +120 V	120 Hz	17 W

10.1.3 Ambient Conditions and Classifications

The following ambient conditions and classifications must be observed for the P-62x:

Area of application	For indoor use only
Maximum altitude	2000 m
Air pressure	1100 hPa to 0.1 hPa (corresponds to roughly 825 torr to 0.75 torr)
Relative humidity	Highest relative humidity 80% for temperatures up to 31°C Decreasing linearly to 50% relative humidity at 40°C
Operating temperature	-20°C to 80°C For versions without sensor (P-62x.x0L): -20°C to 150°C
Storage temperature	-20°C to 80°C
Transport temperature	-25°C to 85°C
Overvoltage category	II
Protection class	I
Degree of pollution	1
Degree of protection according to IEC 60529	IP20

10.2 Dimensions

Dimensions in mm. Note that the decimal places are separated by a comma in the drawings.

Standard tolerance according to DIN ISO 2768 - f - H

Roughness Ra 1.6

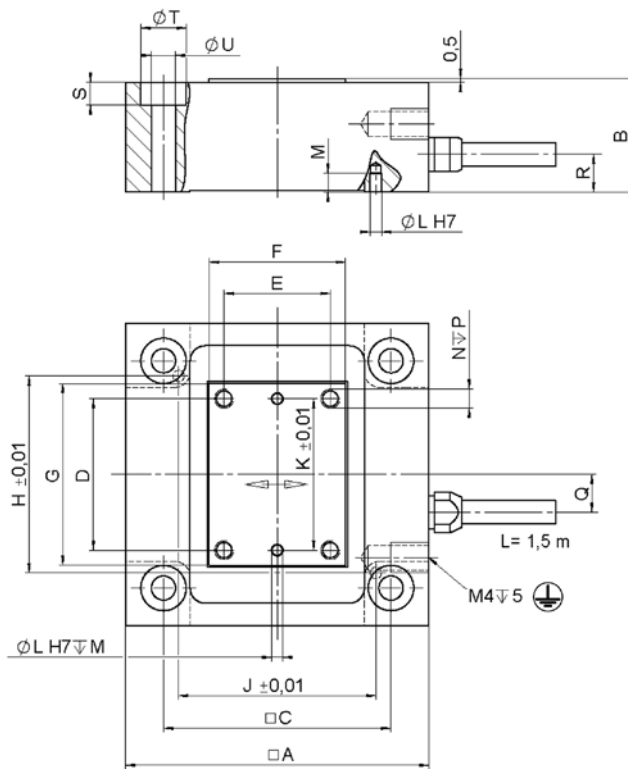

Figure 9: P-62x.1CD / .1CL / .10L / .1UD

⚡ There is no separate protective earth connection on the P-620.

	A	B	C	E	E	F	G	H	J	K
P-620.1xx	30	12	24	15	12	15	18	19	24	15
P-621.1xx	40	15	30	20	14	18	24	26	26	20
P-622.1xx	50	15	40	24	20	25	30	35	35	24
P-625.1xx	60	15	50	40	27	32	44.5	46	46	40
P-628.1xx	80	17	70	58	41	45	63	66	66	58
P-629.1xx	100	22.5	90	60	40	60	84	82	82	60

	Ø L	M	N	P	Q	R	S	Ø T	Ø U
P-620.1xx	1.01	1.5	M2	4	4.5	6	2	4.4	2.2
P-621.1xx	1.51	2.5	M2.5	5	5	5	3	6	3.2
P-622.1xx	1.51	2.5	M2.5	5	5.5	5	3	6	3.2
P-625.1xx	1.51	2.5	M2.5	5	5.5	5	3	6	3.2
P-628.1xx	1.51	2.5	M2.5	5	5.5	5	3	6	3.2
P-629.1xx	2.01	3.5	M2.5	5	10	7.5	4	8	4.3

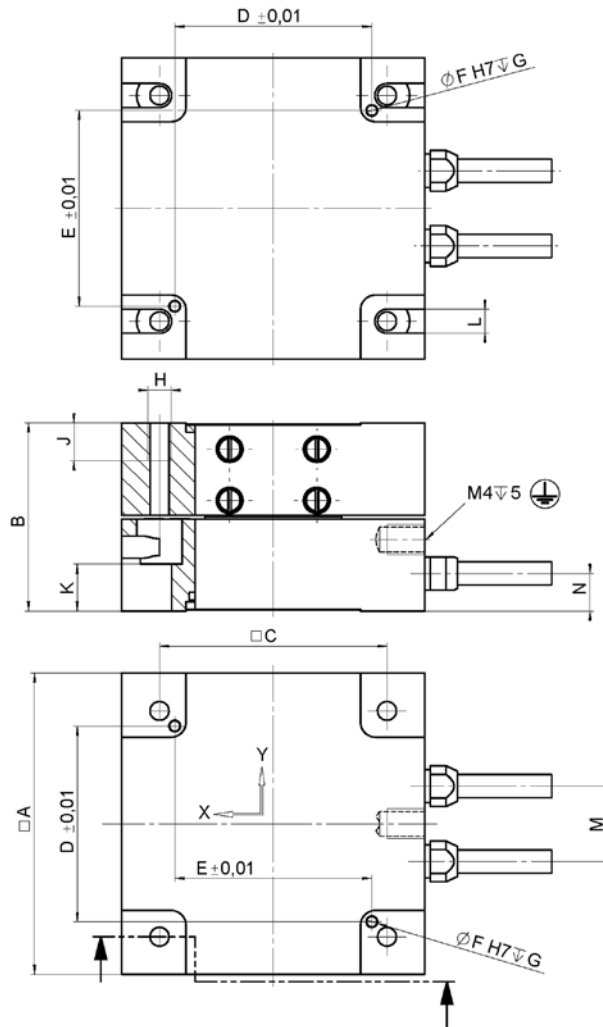

Figure 10: P-62x.2CD / .2CL / .20L / .2UD

⚠ There is no separate protective earth connection on the P-620.

	A	B	C	E	E	Ø F	G	H	J	K	L	M	N
P-620.2xx	30	21.5	24	24	19	1.01	1.5	M2	3.5	5.1	2.2	9	6
P-621.2xx	40	25	30	26	26	1.51	2.5	M3	5	6.25	3.2	10	5
P-622.2xx	50	25	40	35	35	1.51	2.5	M3	5	6.25	3.2	11	5
P-625.2xx	60	25	50	46	46	1.51	2.5	M3	6	6.25	3.2	11	5
P-628.2xx	80	30	70	66	66	1.51	2.5	M3	6	6.75	3.2	11	5
P-629.2xx	100	40	90	82	82	2.01	3.5	M4	7	9.75	4.3	16	7.5

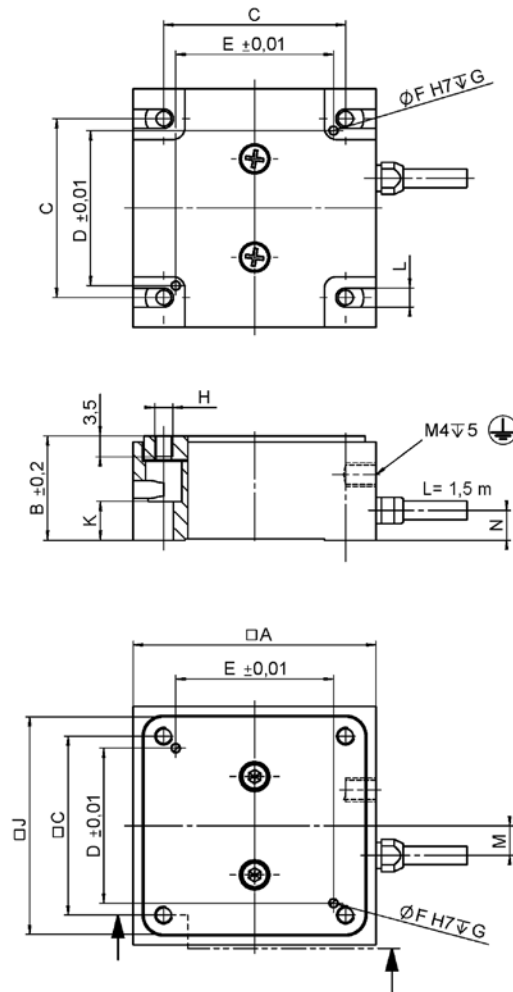

Figure 11: P-62x.ZCD / .ZCL / .ZOL

⚡ There is no separate protective earth connection on the P-620.

	A	B	C	E	E	Ø F	G	H	J	K	L	M	N
P-620.Zxx	30	15	24	19	24	1.01	2	M2	28	5	2.2	4.5	6
P-621.Zxx	40	17.5	30	26	26	1.51	2.5	M3	36.5	6.5	3.2	5	5
P-622.Zxx	50	17.5	40	35	35	1.51	2.5	M3	46.5	6.5	3.2	5	5

10.3 Pin Assignment

7W2 Sub-D mix connector

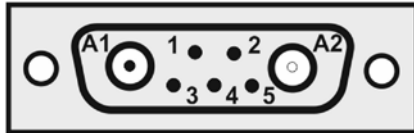

Figure 12: Sub-D mix connector: Front side with connections

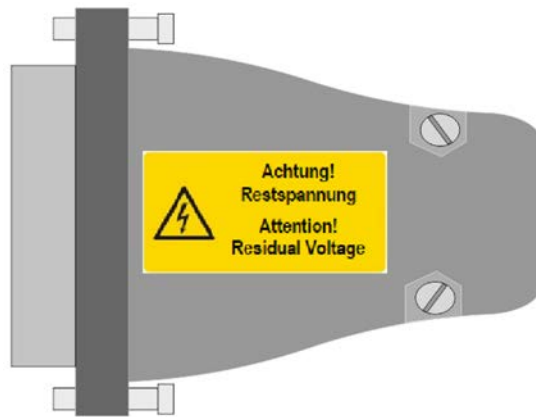

Figure 13: Sub-D mix connector: Top view

Pin	Signal	Function
A1	PZT	Piezo voltage
A2	Probe	Probe sensor signal (moving part of the capacitive sensor)
1	Data ID chip	Data cable for ID chip
2	GND target and ID chip	Ground of target and ID chip
3	GND PZT	Ground of piezo voltage
4	Free	-
5	Target	Target sensor signal (non-moving part of the capacitive sensor)
Case	-	Shield

LEMO coaxial connectors

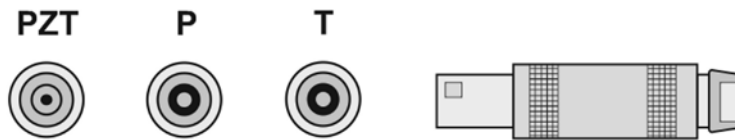

Figure 14: LEMO coaxial connectors

Connector	Signal	Function	Connector shell
P	Probe	Probe sensor signal (moving part of the capacitive sensor)	Cable shield
T	Target	Target sensor signal (non-moving part of the capacitive sensor)	Cable shield
PZT	PZT	Piezo voltage	Ground of piezo voltage on cable shield

10.4 Suitable Piezo Controllers

To operate a P-62x, you need a piezo controller. The device is selected depending on the type of application. The table below lists suitable controllers.

Controller	Channels	P-62x. 1xD	P-62x. 2xD	P-62x. ZxD	P-62x. xCL	P-62x. x0L
E-610 Piezo Driver / Controller (OEM module)	1				x	x
E-625 Piezo Servo Controller (bench-top)	1	x	x ⁽¹⁾	x		
E-665 Piezo Driver / Servo Controller (bench-top)	1	x	x ⁽¹⁾	x		
E-609 OEM Piezo Controller	1	x	x ⁽¹⁾	x		
E-709 Digital Piezo Controller	1	x	x ⁽¹⁾	x		
E-753 Digital Piezo Controller (bench-top)	1	x	x ⁽¹⁾	x		
E-712 Digital Piezo Controller (modular system)	3/6	x ⁽²⁾	x ⁽²⁾	x ⁽²⁾		
E-725 Digital Piezo Controller (bench-top)	3	x ⁽²⁾	x ⁽²⁾	x ⁽²⁾		
E-761 Digital Piezo Controller (PC card)	3	x ⁽²⁾	x ⁽²⁾	x ⁽²⁾		

(1) One controller is required for each axis.

(2) E-710.3D0 adapter cable required (must be ordered separately)

11 Old Equipment Disposal

Since 13 August 2005, in accordance with the EU directive 2002/96/EC (WEEE), electrical and electronic equipment can no longer be disposed of in the member states of the EU with other wastes.

When disposing of your old equipment, observe the international, national and local rules and regulations.

To meet the manufacturer's product responsibility with regard to this product, Physik Instrumente (PI) GmbH & Co. KG ensures environmentally correct disposal of old PI equipment that was first put into circulation after 13 August 2005, free of charge.

If you have old PI equipment, you can send it postage-free to the following address:

Physik Instrumente (PI) GmbH & Co. KG
Auf der Römerstr. 1
D-76228 Karlsruhe, Germany



12 EC Declaration of Conformity

PI

Declaration of Conformity

according to DIN EN ISO/IEC 17050-1: 2005

Manufacturer: Physik Instrumente (PI)
GmbH & Co. KG
**Manufacturer's
Address:** Auf der Roemerstraße 1
D-76228 Karlsruhe,
Germany



The manufacturer hereby declares that the product

Product Name: PIHera Piezo Stage
Model Numbers: P-620, P-621, P-622, P-625, P-628, P-629
Product Options: all

complies with the following European directives:

2006/95/EC, Low Voltage Directive (LVD)
2004/108/EC, EMC Directive

The applied standards certifying the conformity are listed below.

Electromagnetic Emission: EN 61000-6-3: 2007, EN 55011: 2009

Electromagnetic Immunity: EN 61000-6-1: 2007

Safety (Low Voltage Directive): EN 61010-1: 2001

July 21, 2011
Karlsruhe, Germany

Dr. Karl Spanner
President

Physik Instrumente (PI) GmbH & Co. KG, Auf der Roemerstraße 1, 76228 Karlsruhe, Germany
Phone +49 721 4846-0, Fax +49 721 4846-1019, E-mail info@pi.ws, www.pi.ws

PIEZO NANO POSITIONING